



**MAKE EVERYTHING EASIER**





# CDDR15-II

Walkie type electric stacker provides a cost effective solution for applications involving medium lifting storage and short distance pallets transportation.



Conforms to EN ISO3891-1  
EN1175-1  
EN16307-1  
Based on Directive 2006/42/EC  
Conforms to EN Standard 12895  
Based on directive: 2014/30/EU (EMC)

Model	CDDR15-II	
Load capacity	Q(kg)	1500
Load centre distance	c(mm)	600
Load distance, centre of drive axle to fork	x(mm)	697
Fork height, lowered	$h_{13}$ (mm)	90
Tyre size, front	mm	Dia250x70
Tyre size, rear	mm	Dia80x84
Additional wheels(dimensions)	mm	Dia150x60
Wheels, number front rear(x=driven wheels)		1X+1/4
Height, mast lowered	$h_1$ (mm)	1735/1985/2135/2235/2050/2210/2410
Free lift(option2500-3500mm)	$h_2$ (mm)	1300/1550/1700/1800/1570/1740/1940
Max. lift height	$h_3$ (mm)	2500/3000/3300/3500/4500/5000/5600
Height,mast extended	$h_4$ (mm)	2955/3455/3755/3955/5030/5510/610
Height of tiller in drive position min./max.	$h_{14}$ (mm)	670/1300
Overall length	$l_1$ (mm)	1950
Length to face of forks	$l_2$ (mm)	878
Overall width	$b_1$ (mm)	820
Fork dimensions	s/e/l(mm)	60/180/1070(1150)
Width overall forks	$b_5$ (mm)	570/695
Aisle width for pallets 800x1200 lengthways	$A_{st}$ (mm)	2420
Turning radius	$W_s$ (mm)	1575
Travel speed, laden/unladen	Km/h	5.8/6
Lift speed, laden/unladen	m/s	0.11/0.16
Lowering speed, laden/unladen	m/s	0.14/0.19
Battery voltage,nominal capacity Kg(Duplex Mast)	V/Ah	24/240
Battery weight	kg	220
Battery dimensions l/w/h	mm	625x248x500
Service weight(with battery)	kg	1140/1190/1200/1290/1370/1400/1530

Option:  Lithium battery 225AH (Charger 24V/100A)

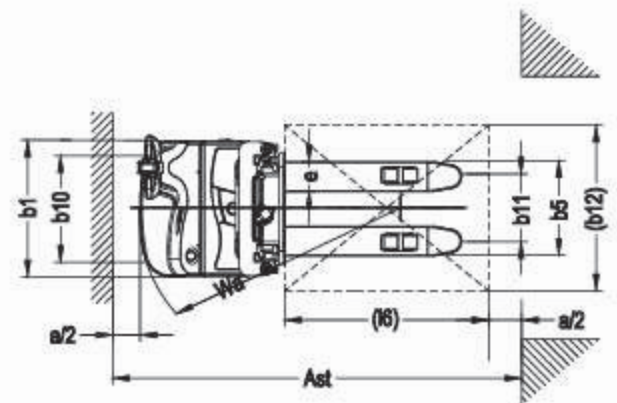
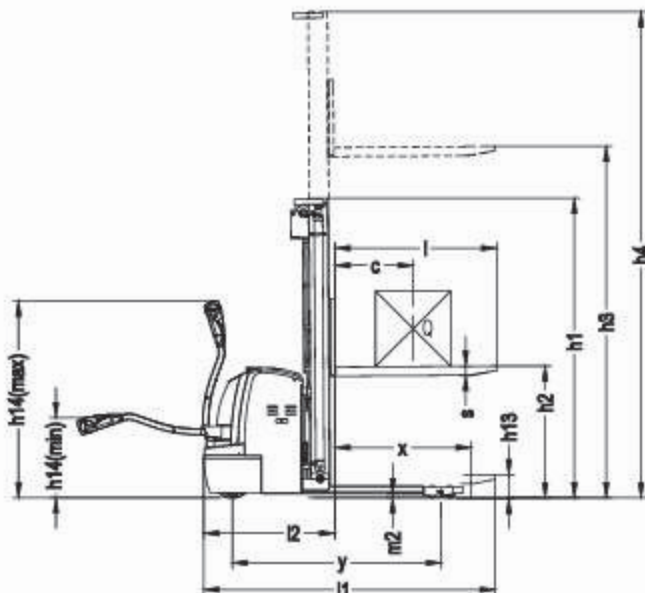

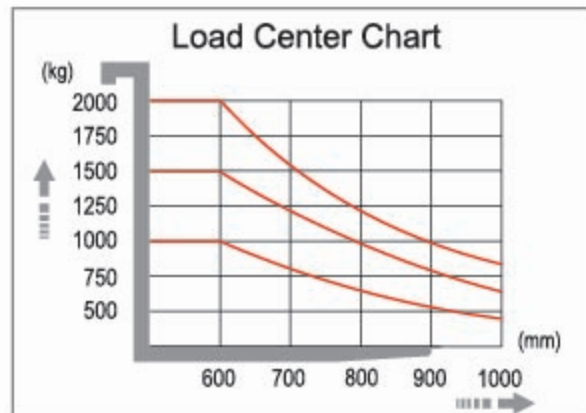
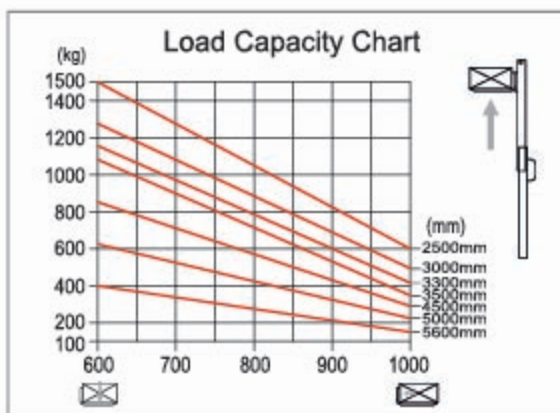

## STRUCTURAL AND SAFETY:

- Advanced AC control system Intelligentized regenerative brake system.
- Multi-function display with BDI and hour meter etc.
- Emergency reversing device.
- Auto deceleration system utilizes regenerative braking.
- Built-in pressure relief valve protects the trucks from overloads.
- Emergency power disconnect .
- Stepless speed control.
- With lifting limit switch to shut off pump motor at the max. lifting height.
- Vertical drive motor has a small turning radius. The motor structure is water-proof and dust-proof.

## STRUCTURAL

- CANbus technology reduces wiring complexity and increase reliability.
- Advanced AC control system with brushless motor.
- Auto deceleration system utilises regenerative braking.
- Side-way battery with oll-out system is very convenient for replacement.

## OPTIMUM STRUCTURAL DESIGN:

- Low barycenter ensures the stable operation.
- Vertical driving wheel ensures convenient maintenance and small turning radius. Water-proof and dust-proof motor structure, keeps the braking and motor more durable and reliable.
- The mast and the frame are dividable and exchangeable.
- Full free lifting, fit for low roof house. (3M lift height truck can enter into a 2M door)



Mast



Vertical Drive Wheel



Option: Initial lifting with double-pallet function



RUYI Handle



Frei tiller head with one side lifting button (option)



Germany Tiller Head with big buttons



TEL: 0086-532-66739792

FAX: 0086-532-66739791

info@movmes.com

NO.88 Chunyang Road,Chengyang,  
QINGDAO,CHINA

[www.movmes.com](http://www.movmes.com)