



MAKE EVERYTHING EASIER





00190022000001102
00190201210000102
00190001210000102



00000
CNAS 0001-Q, L, S



CDDK10-III CDDK12-III CDDK15-II

Electric Rider Stacker

AC

EPS
(Option)



Conforms to EN ISO3691-1
EN1175-1
EN16307-1
Based on Directive 2006/42/EC
Conform to EN Standard 12895
Based on directive: 2014/30/EU (EMC)

Model		CDDK10-III	CDDK12-III	CDDK15-II
Load capacity/rated load	Q(kg)	1000	1200	1500
Load center distance	c(mm)	500	500	600
Load distance,centre of drive axle to fork	x(mm)	600	600	672
Fork height,lowered	h_{13} (mm)	90	90	85
Tyre size,front	mm	Dia250x70	Dia250x70	Dia250x70
Tyre size,rear	mm	Dia80x70	Dia80x70	Dia80x84
Additional Wheels(dimensions)	mm	Dia150x60	Dia150x60	Dia150x60
Wheel,number front rear(x=driven wheels)		1X+2/4	1X+2/4	1X+2/4
Height,mast lowered	h_1 (mm)	2087/1837/2087/2237	2087/1837/2087/2237	1735/1985/2135/2235/2050/2210/2410
Free lift(option2500-3500mm)	h_2 (mm)	∞	∞	1300/1550/1700/1800/1570/1740/1940
Max.lift height	h_3 (mm)	1600/2500/3000/3300	1600/2500/3000/3300	2500/3000/3300/3500/4500/5000/5600
Height,mast extended	h_4 (mm)	2087/3087/3587/3887	2087/3087/3587/3887	2955/3455/3755/3955/5030/5510/6110
Height of tiller in drive position min./max.	h_{14} (mm)	1150/1450	1150/1450	1150/1450
Overall length	l_1 (mm)	1955	1955	2020/2100
Length to face of forks	l_2 (mm)	840	840	950
Overall width	b_1 (mm)	850	850	850
Fork dimensions	s/e/l(mm)	60/170/1070(1150)	60/170/1070(1150)	60/180/1070(1150)
Width overall forks	b_5 (mm)	570/695	570/695	570/695
Aisle width for pallets 800x1200lengthways	A_{st} (mm)	2440	2440	2515
Turning radius	W_a (mm)	1575	1575	1655
Travel speed,laden/unladen	Km/h	7/7.1	7/7.1	7/7.1
Lift speed,laden/unladen	m/s	0.11/0.17	0.10/0.16	0.11/0.16
Lowering speed,laden/unladen	m/s	0.15/0.16	0.15/0.16	0.14/0.19
Battery voltage,nominal capacity K5(Duplex Mast)	V/Ah	24/120	24/120	24/240 24/300(option)
Battery weight	Kg	90	90	220 260
Battery dimensions l/w/h	mm	753x178x240	753x178x240	675x248x500 675x248x545(option)
Service weight(with battery)	Kg	700/750/780/800	800/850/870/890	1240/1270/1490/1520/1560/1580

*The weight shown is for 240AH battery.

Option: With EPS the drive wheel size is 250x80mm



Lithium battery 225AH (Charger 24V/100A)

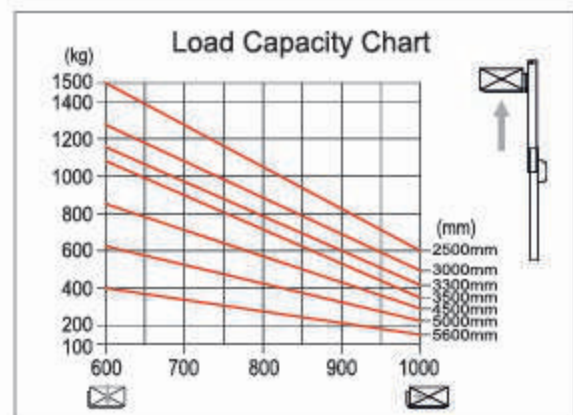
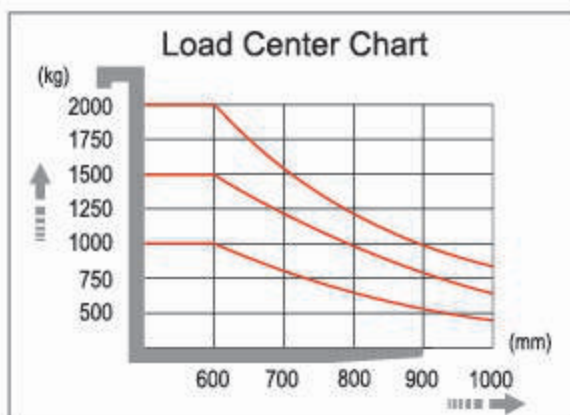

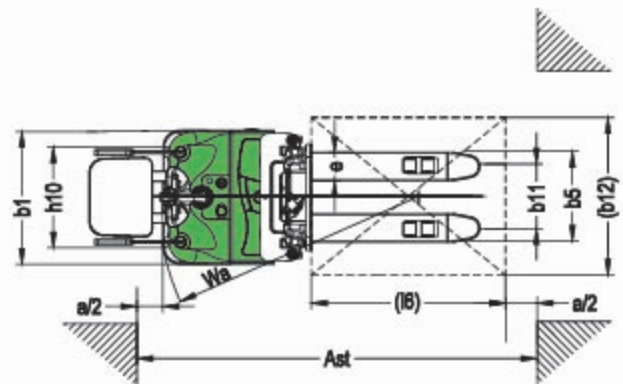
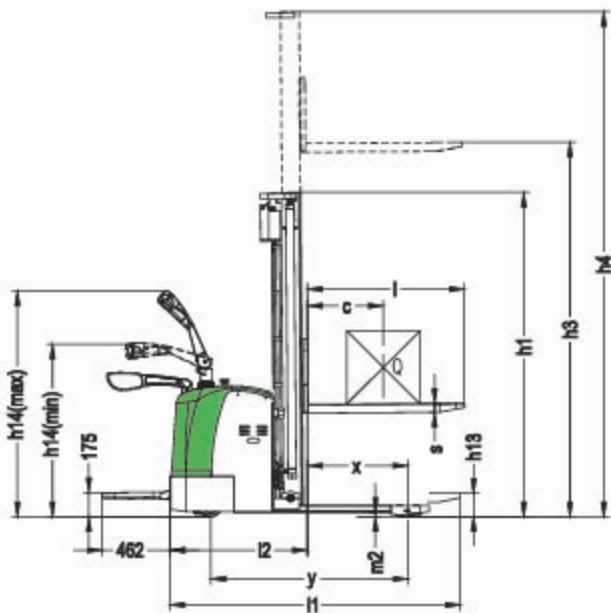



SAFETY AND PRODUCTIVITY

- AC Motor eliminates carbon brush replacement.
- Multi-function display with BDI and hour meter.
- Side way battery is easy to maintain.
- Damping cushion for low-noise operation.
- Emergency reversing device equipped handle to keep safe.
- Auto deceleration function makes operation more safely.
- Built-in pressure relief valve protects the trucks from overloads, increases the reliability.
- With brake in handle upright and horizontal position, increasing the safety of the truck.
- Emergency power disconnect switch.
- Turtle -shaped low speed switch.
- Stepless speed control.

OPTIMUM STRUCTURAL DESIGN

- Low barycenter ensures the stable operation.
- Vertical driving wheel ensures convenient maintenance and small turning radius. Water-proof and dust-proof motor structure, keeps the braking and motor more durable and reliable.
- The mast and the frame are dividable and exchangeable.
- Full free lifting, fit for low roof house. (3M lift height truck can enter into a 2M door)

SERVICEABILITY

- Low voltage protection setting prolongs the battery life time.
- The electronic components' concentrated design simplifies the circuit and makes easily assemble, debug and maintain.



Initial lifting with double-pallet function

Model	Remarks
CDDK15- II	Standard configuration
CDDK10- III/12- III	Economy type (DC brushless)



TEL: 0086-532-66739792

FAX: 0086-532-66739791

info@movmes.com

NO.88 Chunyang Road,Chengyang,
QINGDAO,CHINA

www.movmes.com